



Research Article

SHEAR AND PULLOUT BEHAVIOURS OF STEEL FIBER REINFORCED CONCRETE ON ELEVATED TEMPERATURE

Palani T*

Department of Civil and Structural Engineering, Prist University Puducherry-605007

ARTICLE INFO

Article History:

Received 12th March, 2018

Received in revised form 16th

April, 2018 Accepted 5th May, 2018

Published online 28th June, 2018

Key words:

Shear strength, Pullout (bond) Strength, SFRC, Copper slag and Elevated temperature.

ABSTRACT

Now days in the modern constructions like Nuclear Power Plants, multiplex complex, the bonded reinforcements are often used in conjunction with prestressed steels and in the composite structures, the shear connectors are invariably provided, for which the bond (pull out) strength of concrete is predominant factor. Shear failure is catastrophic as it occurs suddenly without sufficient warning. The bond strength between reinforcement and concrete influences the flexural strength, shear strength and ductility of the reinforced concrete sections. Because of modern life styles, modern electrical equipments the occurrence of fire accidents also increased. Therefore, it is essential to adequately evaluate the shear resistance and pullout strength of reinforced concrete elements during fire conditions to avoid such disastrous mode of failure.

The steel fiber reinforced concrete structures have more resistance against cracking, deflection, spalling, shear and pullouts. SFRC has advantages over conventional reinforced concrete for several end uses in construction. The strength and durability of the concrete increases about 30% when the copper slag is partially replaced up to 40% with river sand as fine aggregate. The use of copper slag in the concrete will be the effective waste management of dumped copper slag and the cost of the concrete also will be reduced.

Copyright©2018 Palani T. This is an open access article distributed under the Creative Commons Attribution License, which permits unrestricted use, distribution, and reproduction in any medium, provided the original work is properly cited.

INTRODUCTION

Interest in the behaviour of concrete at a high temperature mainly results from the many cases of fires taking place in buildings, high-rise buildings, tunnels, and drilling platform structures. Most of the concrete structures are subjected to a range of temperature not severe than that imposed by ambient environmental conditions. However some important structures like Nuclear Power Plant concrete Structures, structures near jet aircraft engine blasting, Chemical Processing units, refractory, building affected by fire accidents, etc are subjected to elevated temperatures. The elevated temperature creates so many negative impacts on mechanical and physical properties of concrete. During a fire, the temperature may reach up to 1100°C in buildings and even up to 1350°C in tunnels, leading to severe damage in a concrete structure. As a result, the cement paste-aggregate bond is the weakest point in heated cementitious material.

Many research efforts are devoted towards the evaluation of concrete properties in compressive strength, flexural strength, tensile strength but only a few efforts to evaluate the shear and pullout strengths behaviors of concrete in the elevated temperatures which also the vital properties to be evaluated.

Why the steel fiber reinforced concrete is chosen?

The steel fiber reinforced concrete is more toughness against fracture and more tensile strength, flexural strength, shear and bond strength than the conventional cement concrete. The steel fiber reinforced concrete structures have more resistance against cracking, deflection, spalling, shear and pullouts. SFRC has advantages over conventional reinforced concrete for several end uses in construction. For fiber concrete, although residual strength was decreased by exposure to high temperatures over 400 °C, residual fracture energy was significantly higher than that before heating. Incorporating hybrid fiber seems to be a promising way to enhance resistance of concrete to explosive spalling. Hence it has been decided to use the steel fiber reinforced concrete in this study.

Why the copper slag as partial replacement as fine aggregate?

From the earlier research works, it is learnt that the strength and durability of the concrete increases about 30% when the copper slag is partially replaced up to 40% with river sand as fine aggregate. When the copper slag is used in the land fill, it pollutes the environment. The use of copper slag in the concrete will be the effective waste management of dumped copper slag and the cost of the concrete also will be reduced.

***Corresponding author: Palani T**

Department of Civil and Structural Engineering, Prist University Puducherry-605007

MATERIALS AND METHODOLOGY

Materials

Fiber Reinforced Concrete

Fiber reinforced concrete (FRC) may be defined as a composite materials made with Ordinary Portland Cement (OPC), aggregate, and incorporating discrete discontinuous fibers. Plain, unreinforced concrete is a brittle material, with a low tensile strength and a low strain capacity. The role of randomly distributes discontinuous fibers is to bridge across the cracks that develop provides some post-cracking “ductility”. If the fibers are sufficiently strong, sufficiently bonded to material, and permit the FRC to carry significant stresses over a relatively large strain capacity in the post-cracking stage.

Definition of fibre types

Metallic fibre, Non metallic fibre, Natural fibre Steel fibres intended for reinforcing concrete are defined as short, discrete lengths of steel having an aspect ratio (ratio of length to diameter) from about 20 to 100, with any of several cross-sections, and that are sufficiently small to be randomly dispersed in an unhardened concrete mixture using usual mixing procedures.

ASTM A 820 provides a classification for four general types of steel fibres based upon the product used in their manufacture:

- Type I- Cold-drawn wire.
- Type II- Cut sheet.
- Type III- Melt-extracted
- Type IV- Other fibres

Advantages of Steel Fibers

- Fast and perfect mixable fibres and High performance and crack resistance. Optimize costs with lower fibre dosages.
- Steel fibres reinforced concrete against impact forces, thereby improving the toughness characteristics of hardened concrete.
- Steel fibres reduce the permeability and water migration in concrete, which ensures protection of concrete due to the ill effects of moisture.
- The first-crack tensile strength and the ultimate tensile strength of the concrete may be increased by the fibers;

Cement

Ordinary Portland cement (OPC) is by far the most important type of cement. The OPC was classified into three grades namely, 33 grade, 43 grade and 53grade depending upon the strength of the cement at 28days when tested as per IS 4031-1988. Ordinary Portland cement of 53 grade cement shall be used in this experimental work. Confirming weight of each cement bag was 50 kg.

Fine Aggregate

The aggregate size is lesser than 4.75 mm is considered as fine aggregate. The fine aggregate shall be combination 60% of river sand and 40% of copper slag. Sand is generally consider to have a lower size limit of about 0.07 mm. Material between 0.06 and 0.002 mm is classified as silt, and still smaller particles are called clay. In our region sand can be found from

the bed of the Thenpennaiyar River. In this project, clean and dry river sand available locally will be used.

Copper Slag

Copper slag is one of the materials that is considered as a waste material which could have a promising future in construction industry as partial or full substitute of either Cement or aggregates. Copper slag is a by-product obtained during the matte smelting and refining of copper.

Advantages of Copper Slag

- Reduces the construction cost due to saving in material cost.
- Reduces the heat of hydration, permeability and demand for primary natural resources.
- Reduces the environmental impact due to quarrying and aggregate mining.

The properties of the cement and aggregates are given in table

Table 1 Properties of Cement, Fine aggregate and Fine aggregate

| Sl.No | Test | River Sand | Copper Slag | Coarse Aggregate |
|-------|----------------------|------------|-------------|------------------|
| 1 | Specific gravity | 2.53 | 3.41 | 2.78 |
| 2 | Fineness modulus | 2.74 | 3.52 | 7.28 |
| 3 | Moisture content (%) | 1.12 | 0.81 | 0.56 |
| 4 | Water absorption (%) | 0.14 | 0.11 | 0.09 |
| 5 | Bulk density (g/cc) | 1.73 | 2.20 | 1.65 |

Coarse aggregate

The aggregates most of which are retained on the 4.75 mm IS sieve are termed as coarse aggregates. In this project coarse aggregates are maximum 20 mm down size is used. The properties of coarse aggregate are given in table 2

Table 2 Properties of Coarse aggregate

| Sl.No | Property | Value |
|-------|------------------|---------|
| 1 | Specific gravity | 2.78 |
| 2 | Fineness Modulus | 7.5 |
| 3 | Water absorption | 0.5 |
| 4 | Particle shape | Angular |
| 5 | Impact value | 15.3 |
| 6 | Crushing value | 18.5 |

Water

The available potable water in our university campus will be used in this project for preparing the test samples.

MIX Design

Concrete machine mix of M25 grade was prepared as per provision in IS:456-2000 using 53 grade cement, sand and copper slag as fine and crushed stone coarse aggregates. Slump test results showed a true slump of 50 mm using standard slump cone. Water cement ratio was maintained 0.40.

Mix Proportions

| Ingredient | weight | Ratio |
|-------------------------------------|--------------|-------|
| Cement | 465.00 kg | 1.00 |
| Fine aggregate | 768.20 kg | 1.65 |
| Sand | 404.63 kg | 0.53 |
| Copper slag | 363.58 kg | 0.90 |
| Coarse aggregate | 1111.52kg | 2.39 |
| Water | 186.00 litre | 0.40 |
| Weight of steel fibre for 3% mixing | 70.34 kg | 0.03 |
| Weight of steel fibre for 4% mixing | 93.79 kg | 0.04 |

METHODOLOGY

The main objective this study is to find out the shear strength and pullout behaviors of the Steel Fiber Reinforced Concrete on the Elevated temperatures. After removing internal moisture as far as possible in the sun light, the cubes will be heated in the furnace up to the required temperature gradually with 100° C increment. The cubes will be heated to required peak temperature and it will be kept for an hour, then cooled to room temperature by natural cooling and will be tested for shear and pull out strength. Similarly the cubes will be tested at the elevated temperature of 300°C, 600°C and 900°C and the result will be compared with the companion cubes result at room temperature without steel fiber reinforcement.

Method of Shear Test

The shear test was conducted on the inverted L shape cubes of size 150mmx 150mm with shear plane of 150x60mm as shown in the figure 1. The shear test has been done in the compressive strength testing machine by applying direct shear by placing 22mm dia. rod placed directly over the shear plane as shown in Figure 2. This type of shear test is simple but most consistent and exhibits most critical type shear and will cause sudden collapse of the structure. Hence this type shear test is selected for the investigation.

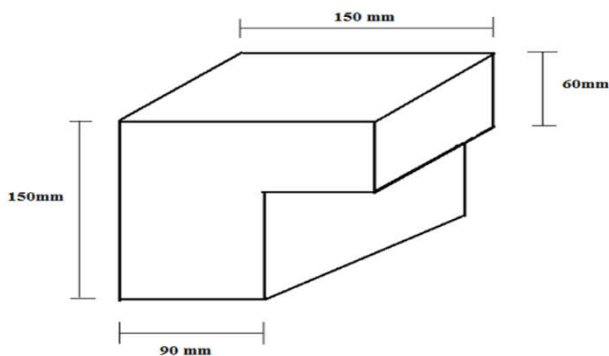

FIGURE 1. CUBE FOR SHEAR TEST

During the direct shear test load carrying capacity was increased till the resistance inhibited by the specimen and sudden fracture was happened in the specimen without the steel fibre while in the specimen with steel fibre, the load carrying capacity increase till the initial crack appears and load carrying capacity remains constant but the strains in the specimens increased and fracture of the specimens has been happened. In the heated specimens above 600° C the coarse aggregates fractured, and leads to the failure of the specimens.

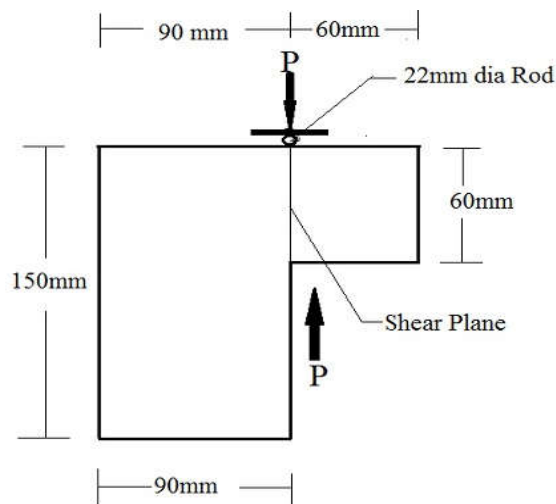

FIGURE 2. SHEAR PLANE AND SHEAR LOAD

Method of Pullout Test

The specimen for the pullout test has been casted with 150x150x150mm size cubes with M25 design mix consists of 3% and 4% steel fibres and companion cubes without steel fibres. To find out pullout strength a 16mm dia TMT bars of total length of 500mm out of which 125mm is embedded in to the concrete as shown in the figure 6. After the curing periods of 28 days the moisture are removed in the sunlight and the specimens were heated to 300°C, 600° c and 900°c and compared with room temperature.

The pullout test was carried out in the Universal Testing Machine (UTM) by the cube was fixed below the lower deck and the rebar was fixed to the upper jaw through the holes in the deck of the UTM and clamped as shown in the figure 7. The tensile load was applied at the rate of 2.50tonnes per minute till the specimen fails. The test setup must be the rebar should not yield due to the tensile load and either the rebar should be pulled out from the cube or cracking of the cube concrete.

It is observed that in the specimen without the steel fibres the failure occurred due to splitting of concrete and fracture happened in the specimen, while the specimen with steel fibres only surface cracks happened and the rebar pulled out from the specimen. When the specimen begins to fail and if there is no resistance in the specimen the reading of loading remains constant and no further movements of the loading indicator of UTM. This load represents the pullout load of the specimen.

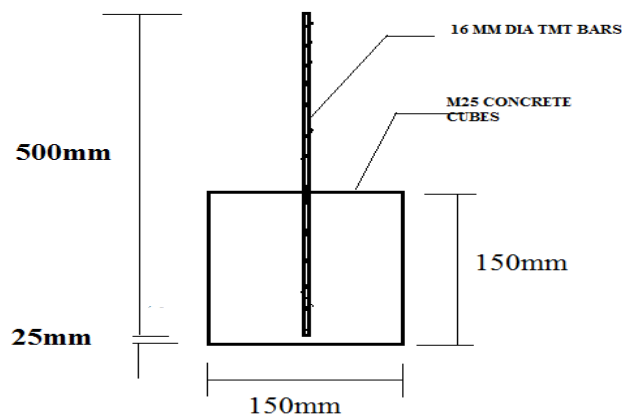

FIGURE 6. CUBE FOR PULLOUT TEST

RESULTS AND DISCUSSION

Visual Inspection of Samples after Testing

Post inspection samples by visual observations were carried out after heating, shear test and pullout test. The colour of the specimen was observed after heating the samples and it was found that dark grey colour of the concrete changed to light grey colour after heating at 300°C and light brownish colour appeared after heating at 600°C and above temperatures. The fractured surface of the concrete was inspected and found that the bluish colour of the coarse aggregate has changed to dark brownish colour and coarse aggregate becomes more brittle and becomes soft nature. The steel fibre became partially brittle nature and surface cracks observed on the surface of the cubes after heating at 600°C and 900°C.

CONCLUSION

In this study the effects of elevated temperature on the behaviors of shear and pullout on the steel fiber reinforced cement concrete with copper slag as partial replacement of fine aggregate is found more efficient in physical as well as mechanical properties than the conventional concrete. The specimen with steel fibres has only surface cracks where as failure occur in the specimen without the steel fibres due to splitting of concrete and fracture happened in the specimen. Steel fiber in the concrete enhances the resistance against explosive spalling during elevated temperature and the use of copper slag in the concrete will be the effective waste management of dumped copper slag and the cost of the concrete also will be reduced. Therefore the use of 3% of steel fibres will be effective in improve of shear, the bond strength and control the elevated temperature.

References

1. Amit Rana (2013), 'Some studies on steel fiber reinforced concrete,' *International Journal of Emerging Technology and Advanced Engineering*.vol.3pp:120-127.
2. Anand N & Arulraj G (2011), 'The Effect of Elevated Temperature on Concrete materials', *International journal of structural Engineering*, vol.1, pp: 928-938.
3. Binaya Patnayak, Seshadri Sekhar T, & Srinivasa Rao, 'Strength and Durability Properties of Copper Slag Admixed Concrete', *International Journal of Research in Engineering*, vol .4, pp:158 -166.
4. Deepak Gowda B & Balakrishna H B (2014), ' Flexural Behavior of Reinforced Concrete Beams by Replacing Copper Slag as Fine Aggregate', *International Journal of Civil and Structural Engineering Research*, vol. 2, pp: 97-103.
5. Eva Lubloy & Balazs L Gyorgyu (2014) 'Temperature effects on bond between concrete and reinforcing steel', *Journal of faculty of civil engineering*, pp: 27-35.
6. Erdogan Ozbay, Hakan T, Turker, Muzeyyen Balckanl & Mohammed Lachemi, (2015), 'Effect of Fiber Types and Elevated Temperatures on the Bond Characteristic of Fiber Reinforced Concrete', *Journal of Civil Engineering, Einvironmental, Structrul Engineering*,vol.9, pp: 500-504.
7. Jonas Gustafsson & Keivan Noghaba (1997) 'Steel Fibers as Shear Reinforcement Stuctural Engineering', *Luleå University of Technology, Luleå Vol.2*, pp:220-226.
8. Joris Fellingner, Jan Stark, & Joost Walraven (2005), 'Shear and anchorage behavior of exposed hollow core slabs', *Journal of Heron*, vol.50, pp:279-300.
9. Leema Rose A & Suganya P (2015), ' Performance of Copper Slag on Strength and Durability Properties as Partial Replacement of Fine aggregate in Concrete' *International Journal of Emerging Technology and Advanced Engineering*, vol .5, pp:434-437 .
10. Nguyen Van Chan H (2002), 'Steel fiber reinforced concrete' , *Journal of Civil Engineering, Ho Chi Minh City University of Technology*, vol.1, pp: 108 -116.
11. Sallal Rashid Al-Owaisy (2007), 'Effect of High Temperatures on Shear Transfer Strength of Concrete', *Journal of Engineering and Development*, vol.11, pp: 99-102.
12. Sherif Yehia & Ghanim Kashwani (2013), 'Performance of Structures Exposed of Extreme High Temperature-An overview,' *open Journal of Civil Engineering*, vol.3, pp: 154-161.

How to cite this article:

Palani T (2018) 'Shear And Pullout Behaviours of Steel Fiber Reinforced Concrete on Elevated Temperature', *International Journal of Current Advanced Research*, 07(6), pp. 13572-13575. DOI: <http://dx.doi.org/10.24327/ijcar.2018.13575.2432>
