



Research Article

SIMULATION AND ANALYSIS OF SUB SAMPLED FILTER BANK DESIGN FOR MULTIMODAL MEDICAL IMAGE FUSION BASED ON WAVELETS TRANSFORMATIONS

Subhashini Bollineni*, Gowripriya Chintala and Bhaskar Rao

Department of ECE, GIST, Nellore, Andhra Pradesh

ARTICLE INFO

Article History:

Received 10th February, 2018

Received in revised form 6th

March, 2018 Accepted 24th April, 2018

Published online 28th May, 2018

Key words:

Image synthesis, nonsubexperimented direction filter bank, multi-modal therapeutic image

ABSTRACT

Aiming at solving the fusion problem of the multimodal therapeutic descriptions, a innovative therapeutic appearance synthesis process is present in this paper. The multiwavelet stays united with in the NSDFB to construct the proposed Multi-NSDFB transform. The source descriptions be able to be decayed into several lowpass coefficient then highpass coefficient. And all coefficients can be decayed into four direction subbands. The adapted spatial occurrence is accepted to motivate the pulsation attached neural network to hand picked the every direction subbands factors. For the Research outcomes validate that the proposed algorithm can not only the cause extra significant visual information from the spring images, but also successfully avoid the overview of the artificial information. The present scheme overtakes the redundant detached wavelet transform-based, then the Ripplet transform-based in terms of the both graphic quality besidesof objective appraisal.

Copyright©2018 Subhashini Bollineni et al. This is an open access article distributed under the Creative Commons Attribution License, which permits unrestricted use, distribution, and reproduction in any medium, provided the original work is properly cited.

INTRODUCTION

With the expansion of medical facts, processor science and biomedical tradefacts, the therapeutic duplicate expertise can provide the experimentalstudy with a variety of multi-modal therapeuticdescriptionsby way of the figured tomography, the charismatic reverberation imaging, the solitary photon discharge reckoned tomography (SPECT), the positron release tomography and ultrasonic images [1]. Alteredremedial duplicate can presentation diverse material of the same entrails in the body. For example, The MRI is good at rapid the soft nervevidence than the CT is. Though, the CT image can deliver better indication of nerve calcification besidesjaw segment than the MRI can. In the clinic submission, a only modal of medical image often cannot offerad equate evidence to doctors to make the right investigation. It is required to combine different modal imageries to unique duplicate with satisfactory indication of source imageries. The fused therapeutic imageries can contain the active indication from the numerous modal descriptions to authenticate the inclusive indication of contaminated nerve or magazines. At the similar time, the completed indication in the causeimageries is nullified. Hence, the doctor can easily type an accurate judgement or regulate the exact comforting scheme.

Nowadays, many therapeutic image synthesis methods has been planned such as intensity-hue-saturation (ISH) transform[4-5], principal component study(PCA), Bovey transform.

In adding, the approaches created on multiscale analysis (MCA) methods has been planned in the latest including the laplacian transmute, the discrete wavelet transmute(DWT) [6], the nonsubexperimented contourlet transmute (NSCT) [7] and shearlet transmute [8]. The boundaries of wavelet direction make it does not perform well multi-dimensional data such as duplicate. Therefore, DWT-based fusion schemes cannot reserve the outstanding topographies of the source imageries efficiently [9]. Besides, the idleness in shearlet [10] and NSCT [11] putrefaction make the runtime very slow in duplicate processing including image synthesis, although the shearlet and NSCT can capture the point discontinuities of image and track the curve directions of images. In comparison with wavelet transform, the multiwavelet is orthogonal and symmetric but retains the property of solid funding [12]. However, it is problematic to rapid the geometry edifices of images in consideration of the multiwavelet is isotropy distinguishing. The no subsampled direction filter bank (NSDFB) [13] has shift-invariant property because the downsampling and upsampling in the direction filter bank (DFB) [14] is eradicated in NSDFB. Hence, the NSDFB is iteratively employed in NSCT to decay the image into many directions. Stimulated by the fact that the laplacian transmute is combined with the directional filter bank in Contourlet transmute[14], we propose a new double multi-resolution and multi-scale illustration method named as Multi-NSDFB transform that the multiwavelet transform is communal with NSDFB in this broadside. In Multi-NSDFB transmute, the duplicate is disintegrated into a low-pass subband besides three high-pass subbands by the multiwavelet transmute and the NSDFB is laterachieved to decay the every subband into

*Corresponding author: **Subhashini Bollineni**
Department of ECE, GIST, Nellore, Andhra Pradesh

several direction constants. Consequently, the Multi-NSDFB transmute is a multi-resolution, multidirectional, multi-scale and anisotropic entrance for successfully snatching the detailed indication in multimodal therapeutic imageries.

Existing Method

Intensity Hue Saturation

When a ray of elegant comprising various movement lengths raids the eye, its rejoinder is not enumerated through the measure of the replies that would remain moulded by means of unique of the element movement lengths momentary unaided. Even though nearby are various dissimilar deliveries of movement lengths that be able to be untried, our procedure of the entries of these supplies be able to be uttered by means of a temperately small number of boundaries. That is, there are countless diverse groupings of movement lengths which seem to return the similar visual color.

Though a quantity of dissimilar approaches can be recycled to illustrate a mixture of movement lengths, it tries available that altogether of them use several 3 or 4 boundaries. This is not a happenstance, later this small quantity of restrictions is allied to the way the eye signs color. The diffident triad of boundaries are called *hue*, *surplus* and *power*.

Uncertainty we breakdown and about a ray of graceful into each of its module movement lengths and uncertainty we design the amount of each factor in place of a occupation of movement length, at that moment, lightly discourse, the variety is the highest of this scheme – the movement length (or moderately slight posse of movement lengths) which abstains the punishing asset. The hue is usually the isolated announcement that we would use to label a merged reddened. Kind tenets series commencing approximately 440 nm for violet, 450 nm for blue, up and around to nearby 700 nm cast off on behalf of red light. The names coupled with altered kinds keep an eye on the supernatural crumbling of a rainbow: red, orange, yellow, green, blue, and violet. These expressive standards are accompanying with assortments of affinity lengths reasonably than with single tenets, and unambiguous individuals can grasp flags exterior of this likely series of movement lengths (*ultra-violet* thru a movement length squatter than violet or *infra-red* with a movement length longer than red).

The surplus of a ray of bright is ordered to the depth of the scheme of benefit vs. Measure length categorised above. A entirely flooded ray would take solitary one and only movement length and would be called unicolor, which a entirely unsaturated ray would comprise all inclination lengths now equivalent quantity in addition would seem white. A wholly soaked ray so has a precise light passion scattering utility (possibly consisting of individual one non-zero rate vouching the limit), which a entirely unsaturated ray devours a precise extensive dispersion role, conceivably involving of a persistent assessment over greatest or all of the visible variety.

The deliberation be situated linked route for the asset of the bright ray. Passion is very complicated to stipulate because the superficial are and the authentic are can fluctuate suggestively. Lightly discourse, amount is correlated to the over-all supremacy in the graceful ray as measured by some detached mechanism (such as a precise imbler rhythm), but the professed glare of a graceful (or dexterity of a surface) is strappingly predisposed by lots of form reasons in addition

cannot always be quantified tangibly. These areas remain often not self-directed of every other. Meant for instance, the passions well as hue of a ordinary graceful shoot are allied through the black-body collaborations – declining the productivity passion of a gloomy physique also transferrals the hue on the tactic to extensive movement lengths.

Multiscale Analysis

In mathematics and physics, numerous-scale investigation (also called the way of numerous measures) encompasses systems cast off to hypothesis homogeneously valid guesses estimates to the revelations of embarrassment complications, in cooperation for trivial as blooming as heftymorals of the self-determining variables. This is thru by drilling reckless scale and gentle scale variables for an sovereign fickle, and successively pay for these variables, reckless and sluggish, as uncertainty they are sovereign. In the elucidation route of the agitation delinquent from then on, the occasioning bonus free will – familiarized by the newfangled overreign variables – is used to get rid of (undesirable) nonspiritual expressions. The prior deposits freedoms on the ball park elucidation, which existent titled solvability circumstances.

As revealed formerly, the scalability of the Deric he authority exposure manoeuvre varieties it supplementary pliable than the exceedingly indigenous Sobel machinist. The objects in an impact duplicate and the duplicate the aforementioned can consume unlike magnitudes and determinations so a mountable machinist is obligatory to examine for superiorities at dissimilar measures. Kelly plus Levine have move toward edge exposure by spread over a Deric-like machinist above frequent measures. By fluctuating the machinist's size, several brink maps (one for every one measure) are obtained and consequently administered in analogous. Senior offers yet unconventional concert in which a solitary superiority plan is moulded by presuming the peak scale of superiority close-fitting for every solitary locus of the rejoinder duplicate and formerly carrying out scale-adaptive edge recognition. In other arguments, the scale of the machinist is varied fittingly at each locus +9 trendy the duplicate.

Though, climbable vergere cognition is too compound to be implemented promptly. Moreover, consequent operatives (i.e., for figuring symmetric enclosure) potency also be computationally ineffective when they are climbed. One "solution" to this dispute is to gauge the effort copy in its place of broadening the operatives themselves. Thus, a pyramid is moulded after a solitary effort copy by tumbling it by numerous gauge factors. The ensuing usual of mounted descriptions can then be processed by an operative of stable extent (such as the Sobel operative).

Certain an copy $I(i,j)$ of extents $M \times N$, a mounted form, $I_s(i,j)$, of the copy at a gauge feature of s can be attained with extents $[M/s] \times [N/s]$ by which ever subsampling the copy or deputise be around it. The subsequent designates the process essential for mounting by an numeral feature s (though non-numeral mounting is probable as well).

Shearlet Transform

With the development of remedial skill, remedial descriptions play an increasingly vital role in remedial diagnostics. CT and MRI are both the very substantial imaging methods. However,

based on distinct remedial imaging principles, unlike remedial descriptions can reflect distinct info about human organs. In addition, more info about lesions location can be read from the images. Various remedial descriptions can provide more complementary info. For example, CT descriptions are very clear for bone imaging, and they has comparatively low divergence for lenientnerve; while, MRI descriptions can better show the lenientnerve and the relevant vessel. The goal of multi-modal remedial copy synthesis skill is to put all the multi-source copyinfo together so as to provide a more comprehensive and effective info. Then, remedial copy synthesis can solve the delinquent that the copy attained from a single imaging modality can't provide enough info. At the same time it can provide a more exact and valuable reference for the remedial diagnosis and treatment.

Recently, the copy synthesis procedures based on multi-gauge corrosion have been widely applied in remedial copy synthesis, and the Shearlet transform is one of them. Li Bin and Wang Lei introduced the non-sub sampled Shearlet transform (NSST) to the synthesis of MRI/SPECT descriptions and CT/PET descriptions in. Shearlet is one of the state-of-the-art MGA tools. From the point of view of estimate theory, the Shearlet form a tight frame of well localized waveforms at various gauges and directions, which are the true 2-D sparse representation for descriptions with limits. At present, only Curve let has the similar properties. However, the implementation procedure of Curve let is too complex to be achieved within the context of multiresolution analysis of the image. Compared with Contour let and NSCT, the Shearlet transformation has the similar execution process, but it hasn't the restrictions about the number of direction and size of support base. In addition, distinct the NSCT, the inversion of the discrete Shearlet transform only requires a summation of the shearing filters rather than inverting a directional filter bank, which suggests that the execution of the Shearlet has further computational efficacy.

Proposed Method

NSDFB

NSDFB is a new kind conundrum groups used in the nonsub appraised contourlet transform. Here are two modules for the two-conduit quincunx'sconundrum groups then the shearing procedure in the NSDFB. The 2-D descriptions can be divided into the plane commands and the erectpath by the two-conduit quincunx'sconundrum groups. The second module is executed before the end of the corrosion of quincunx'sriddling, thenafter the composite phase, it conducts an anti-shearing procedure. Its utility is reordering the copy sampler. Actually, the shearing procedure is a kind of copy sampler. After this procedure, the copy is revolved and the width becomes twice wider then before. The key of NSDFB is that combines the shearing procedure with the quincunx'conundrum groups in the points of tree-structure. To achieve multi-pathcorrosion, the NSDFB is iteratively used. Figure 1 illustrates a four-conduitmaneuvering corrosion.

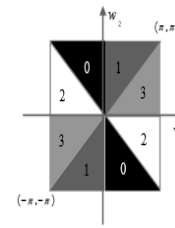

Figure 1. Frequency Partitioning of Four-Channel Direction NSDFB

The Multi-NSDFB Transform

Other than the NSCT [6], the multiwavelet be situated combined thru the NSDFB named for instance Multi-NSDFB transmute is present. An duplicate is firstly disintegrated into a low-slung pass sub band and three in elevation pass subbands by the multiwavelet transmute. Because multiwavelet is orthogonally and symmetrically and possesses the property of condensed maintenance, every subband above is subsequently decomposed into several steering subbands by the NSDFB. Fashionable this broadside, the binary levels disintegration of the multiwavelet is used. After that, every subbands of multiwavelet is disintegrated to four directions by the NSDFB. The putrefaction advancement can undoubtedly be designated in the Figure 2.

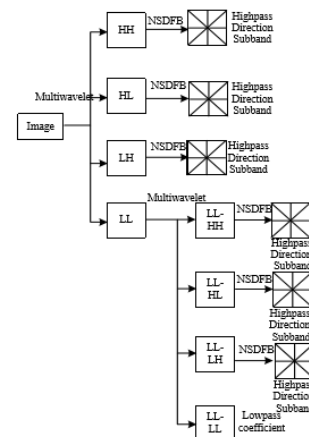

Figure 2. Multi-NSDFB Decomposition of the Image

Proposed Fusion Algorithm

1. The proposed Multi NSDFB transmute are used to fester the source therapeuticimagingins, respectively.
2. Work out the $MSF_B^{l,k}(u, v)$ and $MSF_A^{l,k}(u, v)$ of every subband separately.
3. Adopt the $MSF_B^{l,k}(u, v)$ and $MSF_A^{l,k}(u, v)$ to motivate the PCNN, respectively. Firing times $T_{A,uv}^{l,k}(n)$ and $T_{B,uv}^{l,k}(n)$ should be calculated by:

$$T_{u,v}^{l,k} = T_{u,v}^{l,k}(n - 1) + Y_{u,v}^{l,k}(n)$$

When the iteration process stopped the decision map then the coefficients can be fused by:

$$D_{F,uv}^{l,k} = \begin{cases} 1 & \text{if } T_{A,uv}^{l,k}(n) \geq T_{B,uv}^{l,k}(n) \\ 0 & \text{if } T_{A,uv}^{l,k}(n) < T_{B,uv}^{l,k}(n) \end{cases}$$

$$Multi_{F,uv}^{l,k} = \begin{cases} Multi_{A,uv}^{l,k} & \text{if } D_{u,v}^{l,k} = 1 \\ Multi_{B,uv}^{l,k} & \text{if } D_{u,v}^{l,k} = 0 \end{cases}$$

The $Multi_{F,uv}^{l,k}$, $Multi_{A,uv}^{l,k}$ and $Multi_{B,uv}^{l,k}$ are the quantity of the merged metaphors F, foundation duplicate A and source image

B located at the u-th row and v-th column in the l-th scale and k-th bearing subband, respectively.

4. As a final point, the inverse Multi NSDFB transmute are adopted to modernize the stuck therapeutic imageries by $Multi_{F,uv}^{l,k}$.

RESULTS AND DISCUSSION

To appraise the concert of the proposed blending rule, five tryouts have been accomplished as shown in Figure 3, respectively. These imageries are characterized in three different groups: 1) CT-MRI, 2) MR-T1 MR-T2 and 3) MR-GAD MRI-T1 images. The group d in Figure 3 are MRI-T1 and T1-weighted MR-GAD images though the cluster a, b and c cutting-edgeSymbol 3 are T1-weighted MR image (MR-T1) and T2-weighted MR image (MR-T2), respectively. The assemblage e in Numeral 3 is the CT besides MRI metaphors, in that order. The resultant pixels of two feedback imageries have been perfectly matched. All images have the matching size of 256×256 pixel, with 256-level gray scale.

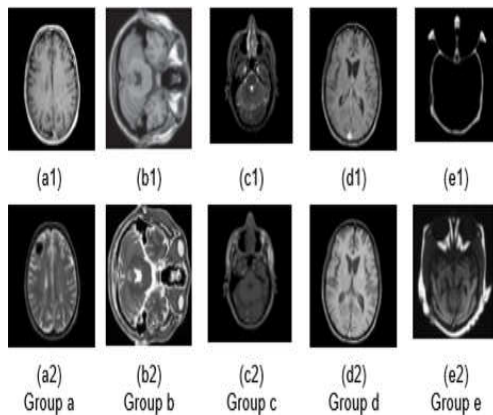

Figure 3 Several kinds of Multimodal Medical Images

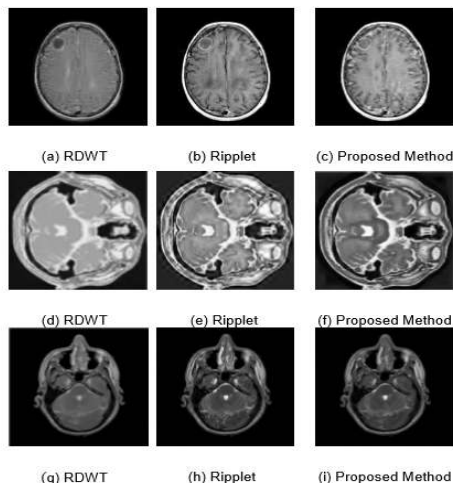

Figure 4 The Fusion Results of MRI-T1-MRI-T2

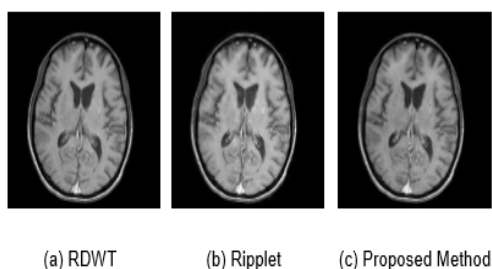

Figure 5 The fusion results of MRI-T1-MRI-GAD

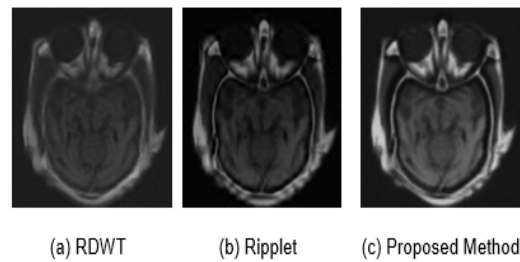

Figure 6 The Fusion Results of CT-MRI

Software matlab

MAT-LAB is a in elevation routine morphological for mechanical figuring. It assimilates calculation, conception, in addition program design in an relaxed to use atmosphere wherever glitche sand solutions are expressed in conversant scientific symbolization. Representative practices consist of:

1. Mathematics and reckoning
2. Procedure enlargement
3. Show off, reproduction, and prototyping
4. Data examination, survey, and conjuring up
5. Meticulous and manufacturing graphics
6. Submission progress, as well as graphical manipulator crossing pointedifice

MATLAB is an communicating organization whose rudimentary facts component is an collection that will not fixes necessitate dimensioning. This permits you to resolve many methodological figuring glitches, expressly those with medium and trajectory preparations, in a segment of the while it would .revenue to transcribe a sequencer in a scalar non communicatingphilological such as C or FORTRAN.

The appellation MAT-LAB brushness for environment laboratory. MATLAB was originally written toprovide informal access to environment software advanced by the LINPACK fashionable totaling EISPACK projects.

Today, MATLAB practices software industrialized by the LAPACK in addition to ARPACK developments, which composed portray the state of the art in software intended for medium computation.

MATLAB has progressed finished a old-fashioned of centuries with effort after numerous manipulators. In institution of higher education surroundings, it is the typical instructional implement for preparatory and unconventional courses inarithmetic, manufacturing, and knowledge. In commerce, MATLAB is the implement of high-quality for in stature effectiveness examination, increase, and enquiry.

MATLAB landscapes a private of submission explicit solutions entitled toolboxes. Very imperative to furthestmost employers of MATLAB, toolboxes permit to absorb and put on focused technology. Toolboxes be situated inclusive atherings of MATLAB utilities (M-files) that Encompass the MATLAB atmosphere to explain vague programmes of snags. Zones in whichtoolboxes are accessible containindication dispensation, controller organizations, neural systems, ambiguous logic, wavelets, reproduction, and various others.

CONCLUSION

In command to rally the effect of multi modal therapeutic duplicate assortment and proliferation diagnostic accurateness,

a novel therapeutic duplicate mixture set of rules is present popular this paper. The multiwavelet stay sunited thru the NSDFB toward sparadigm the anticipated Multi-NSDFB transmute. The anticipated Multi-NSDFB transmute is not only a 2D imageries parse representation routine but also a kind of improved approximation of duplicate superiority. Furthermore, The Multi-NSDFB transmute has the characteristic of multi-scale, multidirection in addition anisotropy. The experiments of the CT-MRI, MRI-T1-MRI-T2 therapeutic imageries mixture indicate that the suggested fusion scheme is more effective than other image fusion works such as RDWT and Ripplet.

References

1. A. Polo, F. Cattani, A. Vavassori, MR and CT image fusion for post implant analysis in permanent prostate seed implants, *International Journal of Radiation Oncology Biology Physics* 70 (2004) 1572–1579.
2. A.L. Grosu, W.A. Weber, M. Franz, Reirradiation of recurrent high-grade gliomas using amino acid PET (SPECT)/CT/MRI image fusion to determine gross tumor volume for stereotactic fractionated radiotherapy, *International Journal Of Radiation Oncology Biology Physics* 73 (2005) 511-519.
3. T. Tu, S. Su, H.C. Shyu, *et al.*, A new looks at IHS-like image fusion methods, *Information Fusion* 2 (2001) 177–187.
4. K.G. Baum, M. Helguera, A. Krol, Fusion viewer: a new tool for fusion and Visualization of multimodal medical data sets, *Journal of Digital Imaging* 21 (2008)59-8.
5. A. Wang, H. Sun, The application of wavelet transform to multimodality Medical image fusion. In: Proceedings of IEEE International Conference on Networking, Sensing and Control. Ft. Lauderdale, FL, 2006, pp. 270–274.
6. F.E. Ali, I.M. El-Dokany, A.A. Saad, *et al.*, A curvelet transform approach for The fusion of MR and CT images, *Journal of Modern Optics* 57 (2010) 273-286.
7. L. Yang, B. Guo, W. Ni, Multimodality medical image fusion based on Multiscale Geometric analysis of Contourlet transforms, *Neurocomputing* 72 (2008) 203-211.
8. T. Li, Y. Wang, Biological image fusion using a NSCT based variable-weight Method, *Information Fusion* 12 (2011) 85–92.
9. K.H. Guo, Wang-Q. Lim, D. Lambaste, *et al.*, Wavelets with composite dilations and their MRA properties, *Applied and Computational Harmonic Analysis* 20 202-36.
10. M.N. Do, M. Vetterli, The Contourlet transform: an efficient directional ultiresolution Image representation, *IEEE Transactions on Image Processing* 14 (2005) 2091-2107.
11. A.L. da Cunha, J.P. Zhou, M.N. Do the nonsubsampled Contourlet transform? Theory, design, and applications, *IEEE Transactions on Image Processing* 15 (2006) 3089-3101.
12. Q. Miao, Ch. Shi, P. Xu, *et al.*, A novel algorithm of image fusion using Shearlet, *Optics Communications* 284 (2011) 1540-1547.
13. Ch. Deng, Sh. Wang, X. Chen, Remote sensing images fusion algorithm base on Shearlet transform. In: Proceeding of International Conference on Environmental Science and Information Application Technology, ACM, Wu Han, China, 2009, pp. 451–454.

How to cite this article:

Subhashini Bollineni *et al* (2018) 'Simulation And Analysis of Sub Sampled Filter Bank Design for Multimodal Medical Image Fusion Based on Wavelets Transformations', *International Journal of Current Advanced Research*, 07(5), pp. 12920-12924. DOI: <http://dx.doi.org/10.24327/ijcar.2018.12924.2288>
