



**AUTOMATIC UMBRELLA CAR DESIGN BASED ON ERGONOMICS AND USERS**

**Gempur Santoso and Nitabian Iftita Rahayu**

Department of Industrial Engineering, University of PGRI Adi Buana Surabaya  
Jl. Dukuh Menanggal XII/4, Surabaya 60234, Indonesia

**ARTICLE INFO**

**Article History:**

Received 17<sup>th</sup> October, 2017  
Received in revised form 21<sup>st</sup>  
November, 2017  
Accepted 05<sup>th</sup> December, 2017  
Published online 28<sup>th</sup> January, 2018

**Key words:**

Design, Umbrella Car, Automation,  
Ergonomics, Users

**ABSTRACT**

Use of vehicle protection or parking tents is an important factor to prevent damage and safety of vehicles. Because if there is no protector, the car will be exposed to sunlight and rain directly. This will affect the fading of colour and damage to the vehicles. The purpose of this research is to make the design of an automatic umbrella car based on ergonomics and users. Stages of this research include the preliminary research phase, the data collection and analysis phase, and the design phase. Data analysis methods use QFD (Quality Function Deployment). This is to analyze the ergonomic products and user requirements. The result of this research is an appropriate technology of automatic umbrella car design model based on ergonomics and users.

*Copyright©2018 Gempur Santoso and Nitabian Iftita Rahayu. This is an open access article distributed under the Creative Commons Attribution License, which permits unrestricted use, distribution, and reproduction in any medium, provided the original work is properly cited.*

**INTRODUCTION**

Now the number of private vehicles is increasing. It will give impact on the increasing need for garages and parking lots. Some parties need to take action immediately as a solution and business opportunity including the company that produces car protector (parking lot, sunclose, garage) and the developer of public service center. As a tool manufacturer (entrepeneurs), the company is important to always develop its products in terms of quantity and quality in order to be able to meet customers' needs and target companies. From the developer side of the public service center, the developer is important to provide a safe and comfortable parking space for visitors. The safety and comfort of this parking lot is filled from the sufficient supply of land, good parking security system (Githa et al., 2014; Yenni and Patria, 2015), to other facilities and infrastructure such as vehicle guards or parking tents, and parking availability information (Thiang et al., 2009).

Parking tents or vehicle protectors are among the products that are useful for protecting vehicles from UV rays, rain, and other external environments. UV light and rain will cause the color of the vehicle to quickly fade and be damaged, rust on certain parts, and other damage. Since now, there is a lot of research developing parking tents or vehicle protectors design but still few use ergonomics and users as the basis for consideration. Dul and Neumann (2009) and Rahayu (2015) claimed that "ergonomics are concerned in product design and product innovation, either product development or new product creation".

The development of products based on ergonomics and users or voice of customers is very important in the creation of a product fit with human, user-friendly, easy to use, bring benefits, and effective and efficient.

This research has aims to develop an automatic umbrella car based on ergonomics and users.

**METHODOLOGY**

**Preliminary Research Stage**

At this stage, it will do literature studies and initial observations are conducted to find the right issues for research and data.

**Data Collection Phase**

Primary data collection is obtained by observation, measurement, interview and discussion directly to the field. Interviews and discussions involved 10 people, consisting of researchers (ergoers), designers, and users. Consumers or users are directly involved in the design modeling process. Their requirements and needs become one of the factors of consideration and as the basis for decision making in design. Questions that given to users are related to the existing model of car protector design and the initial idea of the design model in this study, such as product operation including product content and automation, product shortcomings and advantages, product materials and other additional accessories. The sketches of initial design are criticised, corrected and modified by users. Ergoers and designers is the presenter, facilitator and decision maker.

*\*Corresponding author: Gempur Santoso*

Department of Industrial Engineering, University of PGRI  
Adi Buana Surabaya Jl. Dukuh Menanggal XII/4, Surabaya  
60234, Indonesia

Secondary data get from literature study, such as get from the internet. One of the secondary data is the Pajero Sport car dimension which is used in the design modeling, as shown in Figure 1 below.

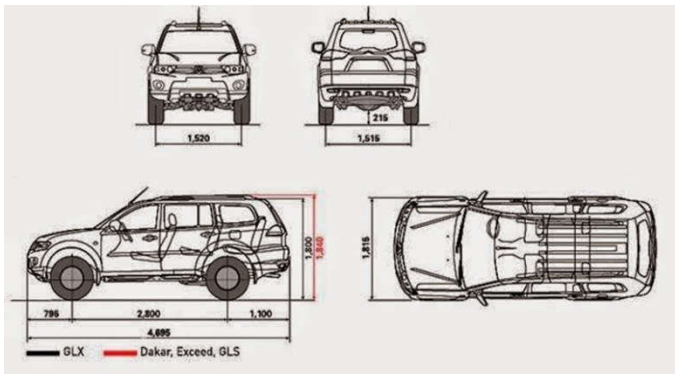

Figure 1 Car dimensions (www.indoblazer.com)

The selection of types car is based on the size of private cars including large cars that have been parked in the front of park of the Faculty of Industrial Technology or sport center University of PGRI Adi Buana Surabaya. This car is one of them. This measure as a sample for the design of umbrella car. The results of this study can be utilized for private cars of similar size and under the type of the car. For the umbrella car design with dimensions of the car under or above this car according to user request (make to order) can use the reference of this research.

**Processing Stage and Data Analysis**

Data analysis in this study using Quality Function Deployment (QFD). QFD is used to get ergonomic design and design models and according to user requirements. QFD is described by a matrix called "House of Quality" (HOQ).

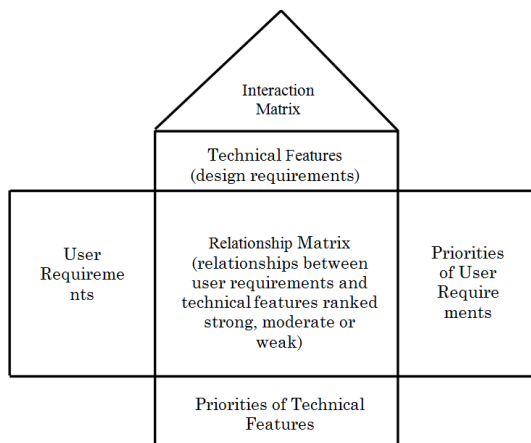

Figure 2 House of Quality Matrix (Demirbilek and Demirkan, 2004)

Relationship scores:

- : 6 (very strong relationship)
- : 3 (strong relationship)
- △ : 1 (weak relationship)

Relative Importance Ranking 1 to 5:

- 141-up = 5
- 106-140 = 4
- 71-105 = 3
- 36-70 = 2
- 0-35 = 1

where; 4 and 5: most important, 3: moderately important, 1 and 2: less important

**Design and Evaluation Design Phase**

At this stage it will do the process of design or manufacture of automatic umbrella car model based on ergonomics and users and then to be continue followed by the design evaluation phase. The design evaluation stage is to give assesment whether the design has appropriate with the model and measure which have decide or yet.

**RESULTS AND DISCUSSION**

**Initial Design Model**

The initial design model of the umbrella car before involving designers and users is as follow:

The initial design model of the umbrella car as see in Figure 3 is the umbrella car model before involves the designer and user. The car protector model is divided into two parts: the permanent part closes and the open part when no car is parked. Two parts will close all when the car is parked. This is a constraint for some users because not all users are able to park their vehicle right place. Users also feel ambiguous to the stage of operation of the product even though using the automation system. There is no safety lock on the initial model, so less secure if the umbrella car is used.

**Results Processing and Data Analysis Using QFD**

Costumer needs or user requirements is translated in the form of matrix calculation or commonly called House of Quality (HOQ). From the identification will known some attributes or user requirements variables such as easy to open, easily closed, easily locked, and robust. Variables for the design requirements include materials, operation stage, color of cover, safety lock, dimensions or size, and color on/off button.

Results of processing and data analysis using QFD are as follows:

Table 1 Classification of design priorities

Most important	Moderately important	Less important
Operating stage (107)	Materials (97)	Dimensions or size (67) Safety lock (45) Color of on/off button (24) Color of cover (4)

Processing and data analysis using QFD as shown in Table 1 known that there are three design classifications that are most important, moderately important, and less important. The most important is the variable of operation phase; materials included of moderately important; while dimensions or sizes, safety locks, on/off button colors, and cloth cover colors fall into the category of less important.

**Design Model of anAutomatic umbrella Car Based on Ergonomics and Users**

The following is an automatic umbrella car based on ergonomics and users. This model is the result of the participation of researchers (ergoers), designers and users. For the dimensions of the umbrella car is based on car dimensions and additional dimensions like dimension of park.

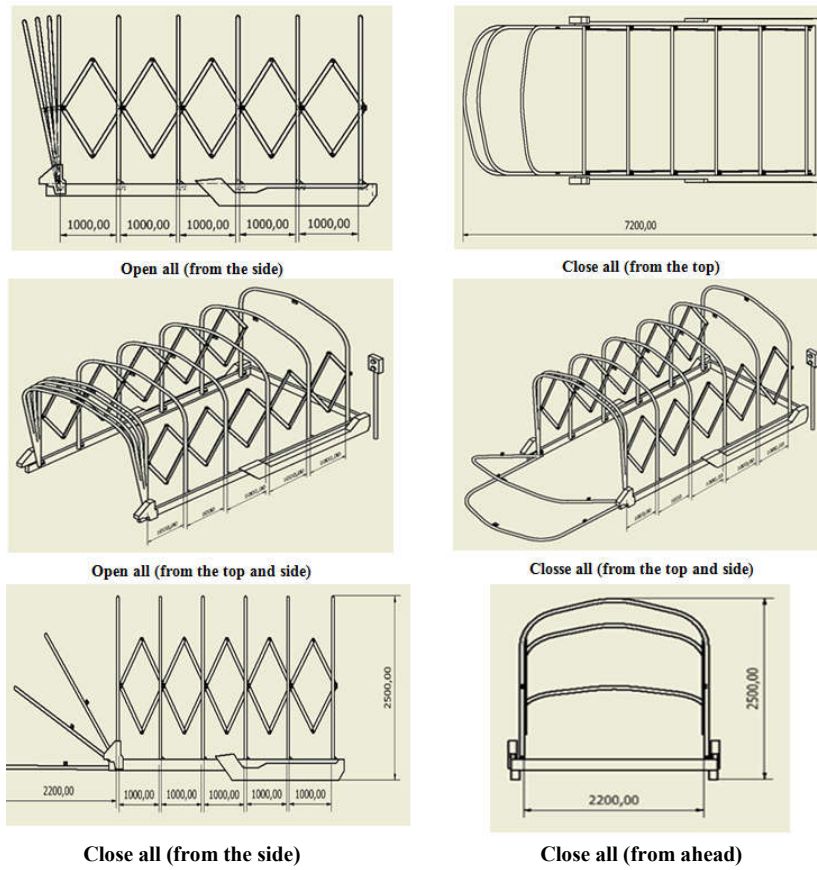

Figure 3 The Initial design model

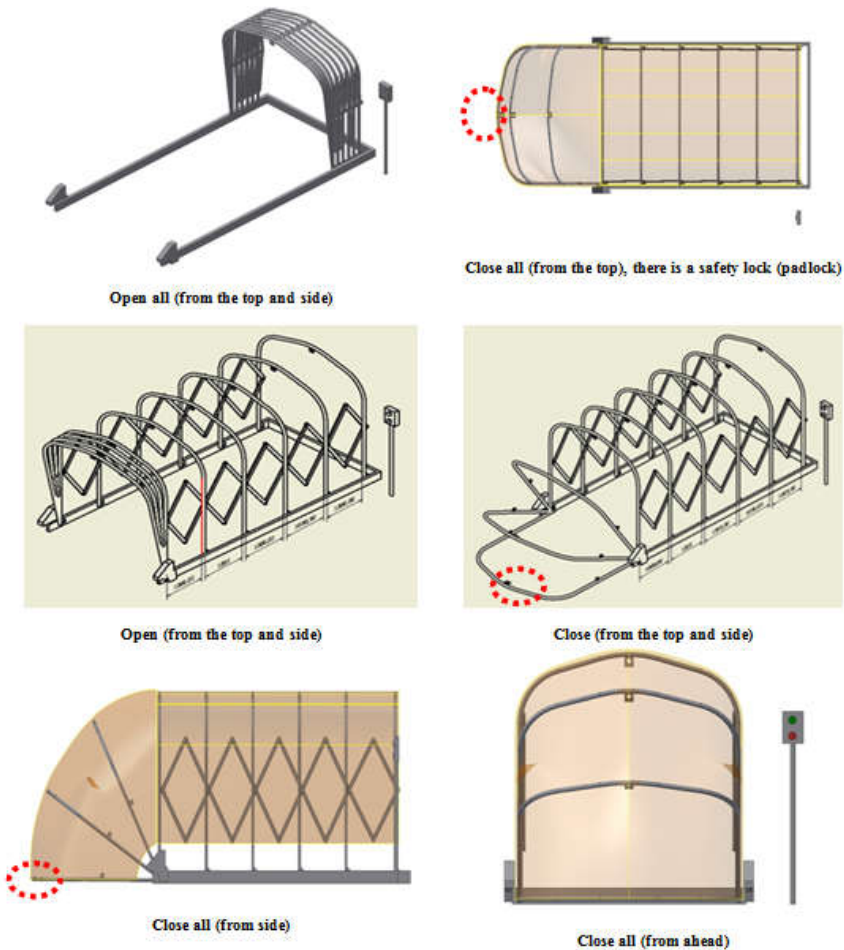

Figure 4 Design model of automatic umbrella car based on ergonomics and users.

Ergonomists or researchers, designers and users participate in the design model. Figure 4 shows that the umbrella car design model is different from the initial design model. The umbrella car is not divided into two parts and neatly on the other end when no car is parked. This makes easier for the user when they will park the car. Accident or collision between car and umbrella car can be minimized. There is a padlock on the end of the umbrella car so safe if the product is used. Ergonomic factors inherent in products such as easy to open, easy to operate, robust, and other factors discussed above are also met. Users will feel comfortable using this automatic umbrella car model.

## **CONCLUSION**

This research has developed innovation of automatic umbrella car based on ergonomics and users. Opinion or voice of customers to the initial design of the product is to produce an ergonomic umbrella car. From the QFD results note that design attributes that get priority consideration is operating stage. The moderately important is materials and the lowest important is dimensions or size, safety lock, color of on/off button, and color of the cover.

## **References**

- Demirbilek, O. and Demirkan, H. 2004. Universal product design involving elderly users: a participatory design model. *Applied Ergonomics*, Vol. 35, hal. 361-370.
- Githa, Dwi, P., Swastawan, and Wayan, E. 2014. Sistem pengaman parkir dengan visualisasi jarak menggunakan sensor PING dan LCD. *Jurnal Nasional Pendidikan Teknik Informatika (JANAPATI)*, Vol. 3, No. 1.
- Rahayu, N.I. 2015. Job Rotation Model Based on Ergonomic Factors, Thesis, Institut Teknologi Sepuluh Nopember Surabaya.
- Thiang, Khoswanto, and H., Sutanto, D. 2009. Sistem tampilan informasi parkir mobil berbasis mikrokontroler. SNIKA 200 Petra.
- [www.indoblazer.com/2015/02/kenapa-ban-depan-dan-belakang-blazer.html](http://www.indoblazer.com/2015/02/kenapa-ban-depan-dan-belakang-blazer.html), accessed at 12/11/2016.
- Yenni, H. and Patria, A. 2015. Rekayasa parking assistance system kendaraan dengan sensor ultrasonik. *JSM STMIK Mikroskil*, Vol. 17, No. 1.

### **How to cite this article:**

Gempur Santoso and Nitabian Ifitita Rahayu (2018) 'Automatic Umbrella Car Design Based on Ergonomics and Users', *International Journal of Current Advanced Research*, 07(1), pp. 8711-8714.  
DOI: <http://dx.doi.org/10.24327/ijcar.2018.8714.1413>

\*\*\*\*\*