

CHANNEL ESTIMATOR AND DIGITAL SELF-INTERFERENCE CANCELLATION FOR FULL-DUPLEX SYSTEMS

Selima Sahraoui, Michael Bocquet, Yassin El Hillali and Atika Rivenq

Department of Opto-Acousto-Electronics of the Institute of Electronics, Microelectronics, and Nanotechnologies, IEMN-DOAE, UMR CNRS 8520, UVHC, F-59300 Valenciennes, France

ARTICLE INFO

Article History:

Received 26th July, 2017

Received in revised form 14th

August, 2017 Accepted 25th September, 2017

Published online 28th October, 2017

Key words:

Full-Duplex, Two-channel estimation, Interference, Digital cancellation.

ABSTRACT

The main target of the next generation mobile networks is to provide high data rates and to overcome the scarcity of the frequency bands. The full-duplex communication allows two users to simultaneously transmit informations on the same frequency band. The most important issue of this system is remove the interference caused by the mobiles transmission signal to its own receive antenna. In this paper, a digital cancellation for a full-duplex communication is proposed. A theoretical approach of the two channels estimation is also studied. The maximum likelihood-based algorithm is used to perform an estimation of the self-interference and intended channels. Moreover, a zero-forcing equalizer is used to restore the signal of interest. Finally, several results based on the mean square error (MSE) and bit error rate (BER) are shown in order to assess the cancellation performance and the estimation efficiency of the proposed method.

Copyright©2017 Selima Sahraoui et al. This is an open access article distributed under the Creative Commons Attribution License, which permits unrestricted use, distribution, and reproduction in any medium, provided the original work is properly cited.

INTRODUCTION

The fifth generation (5G) mobile network is currently under development and actually there is no standard for 5G deployment. Many requirements have to be fulfilled for the wireless based networks [1][2]. Indeed, it will support latency-critical applications as it expects to achieve 5 ms time response [3]. On the other hand, the frequency spectrum is totally allocated and this constrains us to find optimal solutions [4].

In this context, full duplex represents one of the emerging technologies of the future generation. It has been identified as a promising mechanism due to its potential to nearly double the spectral efficiency and significantly increase the transmission rate of wireless systems [5]. In a FD system, a node is able to transmit and to receive simultaneously in the same frequency band and thus leading to increase the spectral efficiency and the end-to-end latency. However, the main drawback of FD system is the high interference resulting from the transmitted signal very close to its proper receive antenna. This self-interference (SI) is several orders of magnitude higher than the signal of interest (SOI) due to the longer distance that the latter signal has to cross compared to the former one [6].

The high power difference between the two received signals make the cancellation stage a major challenge to achieve the

cancellation stage [4]. Passive cancellation aims to achieve a large isolation between the transmit and the receive antennas and thus reducing the SI strength before it arrives to the receive antenna [7][8][9]. The active analog suppression mitigates further the interference power and is mainly used to avoid the overloading. Of the low-noise amplifier (LNA) and the analog-to-digital converter (ADC) [10][11][12]. The digital cancellation, which consists of creating a replica of the transmitted signal and subtract it in the digital-domain, is considered as the lowest complexity of the active cancellation. Some authors have investigated system architectures that use only digital suppression as active cancellation with high enough power reduction for proper signal detection [12][13][14]. In order to reach a maximum suppression and recover the signal of interest, the SI replica has to be as close as possible to the original one including all the distortions that the latter goes through. Thus, the estimate of both the interference and intended channels turn to be a crucial challenge in Full Duplex system. Indeed, pilot allocation and adequate estimator have to be accurately investigated. The two channels are estimated in [15] using an ML estimator and the pilots position are randomly chosen. In [16], the author has estimated the two channels by forcing successively one node to silence and proceed to the CSI acquisition. A least square (LS) estimation is presented in [17], but the authors consider the signal of interest as part of the noise, thus reducing the estimation performances. In this paper, we propose to perform a two-channel estimation for an orthogonal frequency division multiplexing-full duplex (OFDM-FD) system. First, in order to improve the system performance, the ML-based algorithm (ML) is proposed to

*Corresponding author: Selima Sahraoui

Department of Opto-Acousto-Electronics of the Institute of Electronics, Microelectronics, and Nanotechnologies, IEMN-DOAE, UMR CNRS 8520, UVHC, F-59300 Valenciennes, France

reduce the estimation error. Then, a digital cancellation is applied at the digital level and a zero-forcing equalization is used to restore the SOI. Finally, some simulation results show that the intended signal is properly recovered according to modulation scheme and estimation parameters. The rest of this paper is organized as follow: Section II introduces the system model for FD systems. The ML-based channel estimation and the proposed dynamic pilot allocation algorithm are presented in section III. Simulation results showing the performance of our algorithm is presented in Section IV, followed by closing remarks and perspectives in Section V.

Some notations are used as follows: Boldface lower letter to denote vectors and boldface capital letter to denote matrices. Superscript $(\cdot)^T$ and $(\cdot)^H$ stand for transpose and Hermitian respectively. \mathbf{I}_u denotes the identity matrix of order u and \otimes represents the Kronecker product.

System Model

Here, we consider an OFDM-FD system that allows two nodes to transmit and receive signals at the same time over the same frequency band. As depicted in Fig 1, the received signal is composed of two parts: the SI and SOI. These two signals are OFDM modulated. The SI signal can be expressed as

$$x_t^i(n) = \sum_{k=0}^N X^i(k) e^{(j2k\pi n/N)} \quad n = 0, 1, \dots, N-1, \quad (1)$$

where N represents the transmit symbols. We consider M observed blocks, thus the signal can be rewritten as

$$\mathbf{x}^i = [x_1^i, x_2^i, \dots, x_M^i]. \quad (2)$$

We assume that pilot symbols are inserted in some sub-carriers of the SI

$$x_t^s(n) = \sum_{k \in P} X^s(k) e^{(j2k\pi n/N)} + \sum_{k \notin P} X^s(k) e^{(j2k\pi n/N)}, \quad (3)$$

where P denotes the pilot symbols position.

Here, we consider a FD system as shown in Fig. 1. The two nodes communicate in the same time slot and the same frequency band. The receive antenna acquires both the signal of interest and the strong self-interference that has to be removed. Each of them pass through its own channel. The channel impulse response h^i is the time-domain representation of the self-interference wireless channel and h^s represents the impulse response of the channel between the two nodes. Our contribution is made in the digital domain and we suppose that sufficient cancellation have been previously done to prevent the LNA overload. Since the system model is the same for each node, we focus our study on only one terminal.

In this model, each terminal is equipped with a receive and a transmit antenna. The two signals are OFDM modulated and the N transmit symbols X^s and X^i are converted into time domain. After the cyclic prefix insertion, the self-interference signal can be expressed as follows

$$x_t^i(n) = \sum_{k=0}^N X^i(k) e^{(j2k\pi n/N)}. \quad (4)$$

Since we know the SI, there is no need of pilot insertion and the whole signal can be used for the estimation process. We consider M observed blocks in order to perform a more accurate channel estimation.

Concerning the SOI, we insert pilots whose position varies according to the OFDM symbols. For a group of pilot positions P , we can consider the signal as the sum of the two following term and (3) can be rewritten as

$$x_t^s(n) = x_t^{sp}(n) + x_t^{sd}(n). \quad (5)$$

We define the data vector signal as

$$\mathbf{x}^{sd} = [x_1^{sd}, x_2^{sd}, \dots, x_M^{sd}]^T, \quad (6)$$

Where

$$x_t^{sd} = [x_t^{sd}(0), x_t^{sd}(1), \dots, x_t^{sd}(N-1)]^T. \quad (7)$$

The two channels are considered frequency selective with L coefficients defined by

$$\mathbf{h}^s = [h^s(0), h^s(1), \dots, h^s(L)]^T$$

$$\mathbf{h}^i = [h^i(0), h^i(1), \dots, h^i(L)]^T. \quad (8)$$

The received signal after the cyclic prefix removal at one sample can be noted

$$y_t = \sum_{l=0}^L h^i(l) x_t(n-l) + \sum_{l=0}^L h^s(l) x_t^{sp}(n-l) + \sum_{l=0}^L h^s(l) x_t^{sd}(n-l). \quad (9)$$

Considering all the observed blocks, the whole received $MN \times 1$ signal y can be expressed in a vectorial form as

$$y = X_{int} h^i + X_{soi} h^s + X_{soi} h^{sd} + w, \quad (10)$$

where w represents the additive white Gaussian noise, X_{int} and X_{soi} are two $MN \otimes L$ defined as

$$X_{soi} = [X_{soi,1}^T, X_{soi,2}^T, \dots, X_{soi,M}^T]^T \text{ where}$$

$$\mathbf{X}_{soi,t} = \begin{pmatrix} x_t^{sp}(0) & x_t^{sp}(N-1) & \dots & x_t^{sp}(N-L) \\ x_t^{sp}(1) & \ddots & \ddots & \vdots \\ \vdots & \ddots & \ddots & \vdots \\ x_t^{sp}(N-1) & x_t^{sp}(N-2) & \dots & x_t^{sp}(N-L-1) \end{pmatrix}. \quad (11)$$

We define the matrix \mathbf{X}_{int} the same way as \mathbf{X}_{soi} by using the interference signal instead of the SOI.

The set of $MN \times MN$ matrices \mathbf{H}_{SOI} are also defined as follow

$$\mathbf{H}_{SOI} = \mathbf{I}_M \otimes \mathbf{H}_S, \quad (12)$$

where \mathbf{H}_s is the $N \times N$ circular matrices whose first column is the $N \times 1$ vector defined as $[h_s(0), h_s(1), \dots, h_s(L), 0, \dots, 0]^T$.

Two Channels Estimation and Cancellation

In this section, we present a digital cancellation that allows the SOI recovery as shown in the figure. The main idea is to create a replica of the transmitted SI in order to perform cancellation at the receiver part. The copy has to be as close as possible to the original for the sake of limiting the residual interference.

However, this method is not sufficient enough for a good estimation. The ML-based channel estimation can be performed by maximizing the log-likelihood function expressed by

$$f_c(h_i, h_s) = -M \log |C| - (y - Bh)^H C_{inv} (y - Bh), \quad (15)$$

Where $|\cdot|$ is the matrix determinant, C is the covariance matrix of the received signal and C_{inv} is the matrix represented as follow

$$C_{inv} = \mathbf{I}_M \otimes C^{-1}. \quad (16)$$

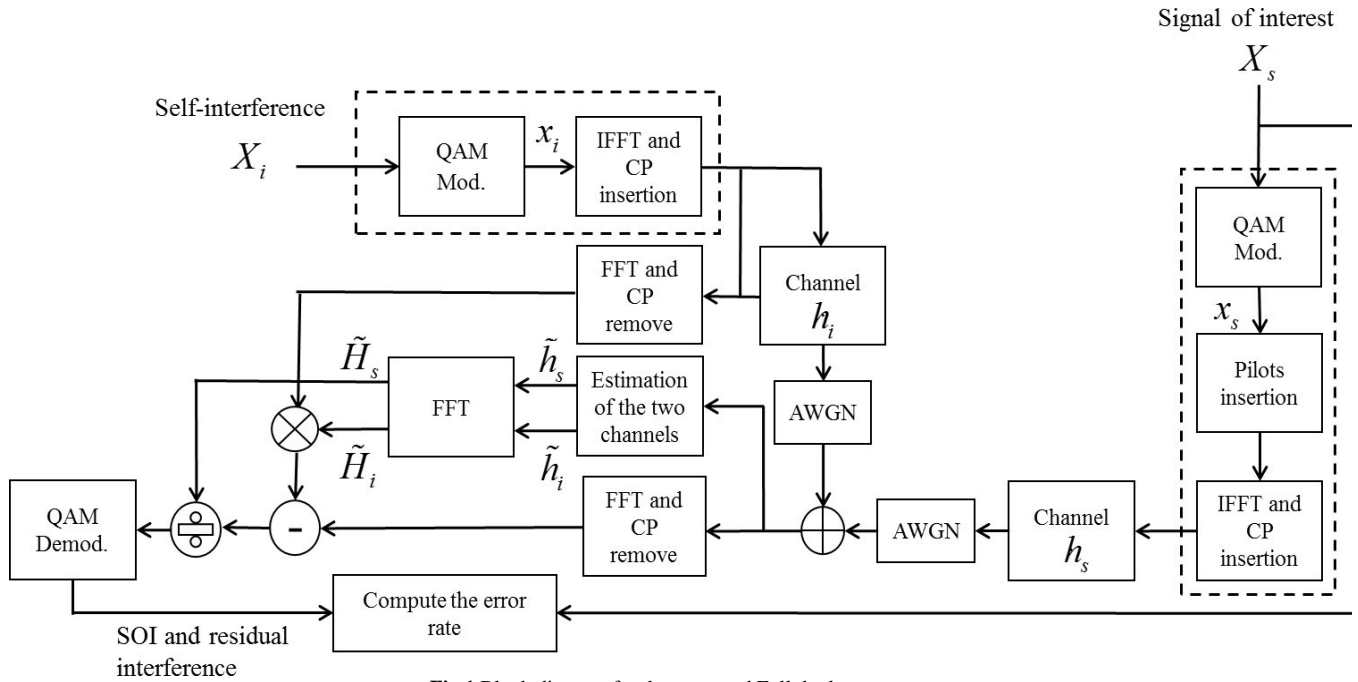

Fig 1 Block diagram for the proposed Full duplex system.

We also have to take into account that the self-interference signal is deformed by many distortions. It is worth noticing that the most important distortion remains the channel effect. In this paper, we only consider the channel as distortion. However, our cancellation scheme, which include an auxiliary chain, allows to introduce different noises to the system and to consider them for future works. Both the two channels estimation have a high impact in how accurate the signal recovery will be. Indeed, a miss estimating of the self-interference channel will lead to a poor cancellation and thus a high amount of residual interference. This latter will impede the signal of interest good recovery. Moreover, the intended channel estimation is no less crucial as it will be used in equalization.

To perform the estimation of the two channels, we rewrite the received signal y as follows

$$y = Bh + H_s x^{sd} + w, \quad (13)$$

where $B = [X_{int}, X_{soi}]$ and $h = [h_i^T, h_s^T]^T$. Note that the matrix B is completely known as it contains the transmitted signal and the signal of interest pilots.

Considering the unknown data as part of the noise we can define the LS estimate as

$$h_{LS} = (B^H B)^{-1} B^H y. \quad (14)$$

Replacing the covariance matrix by its closed form

$$\hat{C}(h) = \frac{1}{M} (y - Bh)(y - Bh)^H. \quad (17)$$

The log-likelihood function can be rewritten as

$$f(h) = -M \log \left| \frac{1}{M} (y - Bh)(y - Bh)^H \right| - MN. \quad (18)$$

As the two channels are unknown, we replace them by the Least square estimate in order to exploit a known covariance matrix so that $C_{LS} = \hat{C}(h_{LS})$. Thus, the estimates of h_i and h_s maximize the new cost function $f(h)$ and after some manipulations, we can obtain the estimate of the two channels as follow

$$\hat{h} = (B^H \hat{C}_{inv} B)^{-1} (B^H \hat{C}_{inv} y), \quad (19)$$

where $\hat{h} = [\hat{h}_i^T, \hat{h}_s^T]^T$ and \hat{C}_{inv} is defined the same way as C_{inv} using C_{LS} instead of C . Once the two channels are estimated, we proceed to cancel the self-interference by creating a replica of the transmitted signal. The copy includes the main impairment applied to the signal which is the channel effect. It is used to be subtracted to the received

signal in order to reduce the higher amount of interference power and lessen it to the noise level. Note that the more accurate the interference channel estimate is, the more efficient the cancellation will be and thus better will be the signal recovery. In order to reduce complexity, the cancellation is proceeded in the frequency domain so that the convolution turns to a simple multiplication. The post-cancellation signal can be written as

$$Y_{pc} = Y - X_{INT} \hat{H}_i, \tag{20}$$

where Y , X_{INT} and \hat{H}_i denote the frequency domain representation of respectively y , X_{INT} and \hat{h}_i .

The final step is to apply an equalizer to the post-cancellation signal in the sake of restoring the signal of interest. The zero forcing (ZF) equalizer consist in applying the inverse of the frequency response of the channel to the post-cancellation signal. The main purpose is to manage the inter-symbol-interference and make a combination with a channel resulting to a flat frequency response. The ZF equalizer can be constructed as follow

$$E_q(f) = \frac{1}{H_s}, \tag{21}$$

where H_s represents the frequency domain representation of h_s so that $E_q H_s = 1$.

Simulation Results

In this section, the performance of our contribution is assessed through BER simulation results and channel estimation. Since we assumed that a previous cancellation has been done in the RF stage, we can consider the same order of magnitude for both the self-interference signal and the signal of interest. Hence, we set the signal-to-interference ratio to 0 db. The symbols are OFDM modulated and the number of subcarrier is set to 64 .

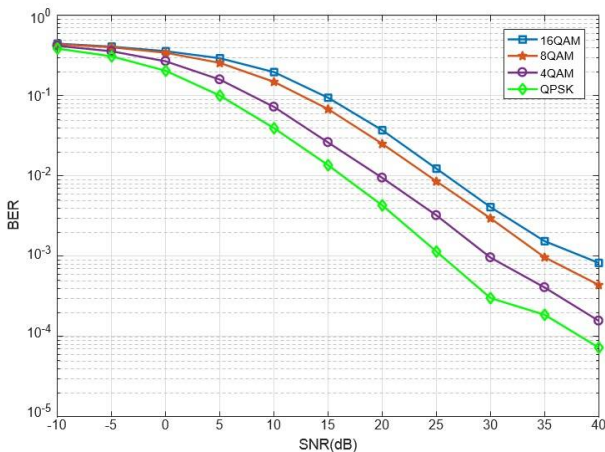

Fig 2 BER vs SNR for different modulations

The two channels h_i and h_s are frequency selective Rayleigh channels defined with multipath $L = 8$ channel taps generated from the Jakes model. The length of the cyclic prefix is fixed to 8 as it has be more or equal the channel

coefficient. We periodically insert the pilots on the subcarriers in the signal of interest with a pilot frequency. In order to obtain more accurate and realistic results, we perform the estimation process over $M = 300$ receiver blocks.

To show the channel performance, we present the MSE of intended channel estimation according to the pilot frequency as shown in Fig. 2. We choose pilot frequency so that the pilot symbols represent respectively 12%, 20%, 25% and 33% . The results indicate that the algorithm efficiency increases with the number of pilot symbols.

However, for a fixed frame length, using a high number of training symbols will negatively impact the system performance as it reduces the number of useful data symbols. We set the pilot frequency to 5 as it represents a good compromise between the estimation performance and the remained number of data symbols.

Fig. 3 compares the MSE of the intended and self-interference channels for both LS and MS estimators. The frequency pilot is fixed to 5 and the symbols are 4-QAM modulated.

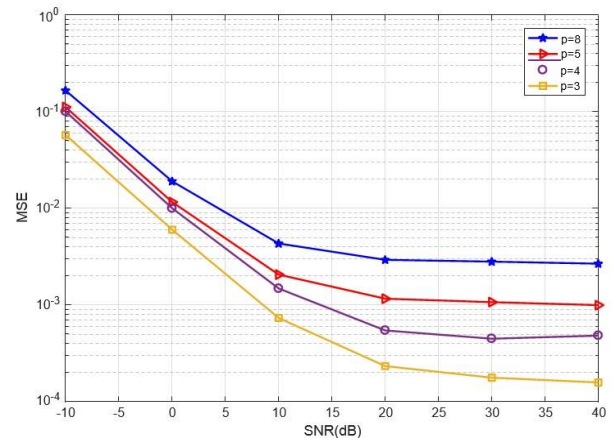

Fig 3 MSE of the estimate intended channel according to pilots frequency

We can easily conclude that the ML estimator outperforms the LS one. This is due to the fact that the ML estimator expression include the covariance matrix estimate of the received signal that allows to reduce the estimation error. Fig. 4 depicts the BER as a function of Signal Noise Ratio (SNR) according to the Signal Interference Ratio (SIR). We can notice that the error increases with the decrease of the SIR.

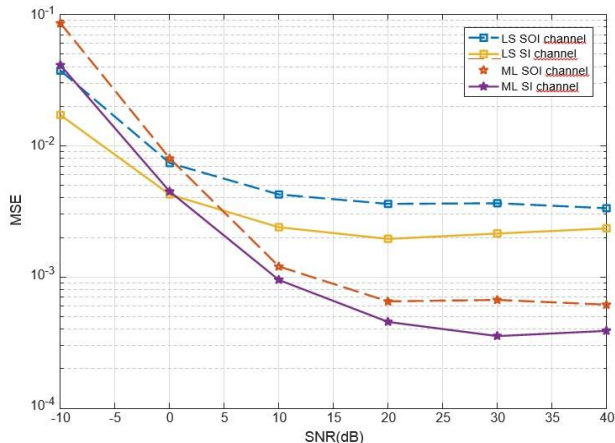

Fig 4 Estimations of the two channels with LS and ML estimators

This is due to the fact that a low SIR lead to a high power of self-interference compared to the intended signals and thus a higher amount of self-interference to be cancelled. Thus, the two signals power are not considered equal anymore and that leads to a poor channel estimation and impacts on the cancellation performance. More residual self-interference also act as additive noise to the post-cancellation signal and clearly weaken the signal of interest recovery.

The last simulation present the modulation effect on the signal of interest recovery as shown in Fig. 5. The BER is presented as a function of the SNR according to different constellations. Results show that the proposed algorithm including cancellation and equalizer reacts the same way as a simple equalization. Indeed, we can notice that the performance decreases with the increase of the cancellation size.

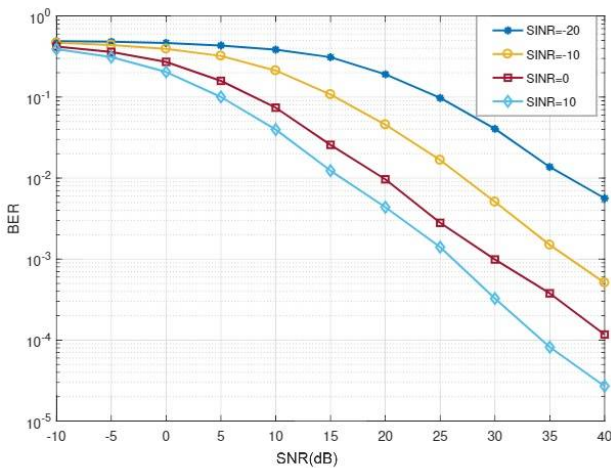

Fig 5 BER vs SNR according to SIR.

CONCLUSIONS

In this paper, we have presented the digital cancellation performance for a full duplex system. The two channels estimation is performed by both LS and a closed form of ML. The estimate self-interference channel is used to create the copy of the distorted signal before subtracting it to receive signal. Then, we exploit the estimate intended channel in order to generate a Zero-forcing equalizer and thereby restore the signal that is transmitted by the other node. A good cancellation is especially performed for high SIR and large SNR range.

References

1. M. Agiwal, A. Roy, and N. Saxena, "Next generation 5G wireless networks: A comprehensive survey," *IEEE Communications Surveys Tutorials*, vol. 18, pp. 1617-1655, third quarter 2016.
2. W. H. Chin, Z. Fan, and R. Haines, "Emerging technologies and research challenges for 5g wireless networks," *IEEE Wireless Communications*, vol. 21, pp. 106-112, April 2014.
3. P. Pirinen, "A brief overview of 5g research activities," in *1st International Conference on 5G for Ubiquitous Connectivity*, pp. 17-22, Nov 2014.
4. D. Bharadia, E. McMillin, and S. Katti, "Full duplex radios," *SIGCOMM Comput. Commun. Rev.*, vol. 43, pp. 375-386, Aug. 2013.

5. M. Duarte, C. Dick, and A. Sabharwal, "Experiment-driven characterization of full-duplex wireless systems," *IEEE Transactions on Wireless Communications*, vol. 11, pp. 4296-4307, December 2012.
6. A. Masmoudi and T. Le-Ngoc, "A maximum-likelihood channel estimator in mimo full-duplex systems," in *2014 IEEE 80th Vehicular Technology Conference (VTC2014-Fall)*, pp. 1-5, Sept 2014.
7. B. Kaufman, J. Lilleberg, and B. Aazhang "Analog baseband cancellation for full-duplex: An experiment driven analysis," *CoRR* vol. abs/1312.0522, 2013.
8. E. Ahmed, A. M. Eltawil, Z. Li, and B. A. Cetiner, "Full-duplex systems using multireconfigurable antennas," *IEEE Transactions on Wireless Communications*, vol. 14, pp. 5971-5983, Nov 2015.
9. C. R. Anderson, S. Krishnamoorthy, C. G. Ranson, T. J. Lemon, W. G. Newhall, T. Kummetz, and J. H. Reed, "Antenna isolation, wideband multipath propagation measurements, and interference mitigation for on-frequency repeaters," in *IEEE SoutheastCon, 2004. Proceedings.*, pp. 110-114, March 2004.
10. A. Sahai, G. Patel, C. Dick, and A. Sabharwal, "On the impact of phase noise on active cancellation in wireless full-duplex," *IEEE Transactions on Vehicular Technology*, vol. 62, pp. 4494-4510, Nov 2013.
11. B. Radunovic, D. Gunawardena, P. Key, A. Proutiere, N. Singh, V. Balan, and G. Dejean, "Rethinking indoor wireless mesh design: Low power, low frequency, full-duplex," in *2010 Fifth IEEE Workshop on Wireless Mesh Networks*, pp. 1-6, June 2010.
12. M. Jain, J. I. Choi, T. Kim, D. Bharadia, S. Seth, K. Srinivasan, P. Levis, S. Katti, and P. Sinha, "Practical, real-time, full duplex wireless," in *Proceedings of the 17th Annual International Conference on Mobile Computing and Networking, MobiCom '11*, (New York, NY, USA), pp. 301-312, ACM, 2011.
13. S. Li and R. D. Murch, "Full-duplex wireless communication using transmitter output based echo cancellation," in *2011 IEEE Global Telecommunications Conference - GLOBECOM 2011*, pp. 1-5, Dec 2011.
14. M. Duarte, C. Dick, and A. Sabharwal, "Experiment-driven characterization of full-duplex wireless systems," *IEEE Transactions on Wireless Communications*, vol. 11, pp. 4296-4307, December 2012.
15. E. Ahmed and A. M. Eltawil, "All-digital self-interference cancellation technique for full-duplex systems," *IEEE Transactions on Wireless Communications*, vol. 14, pp. 3519-3532, July 2015.
16. Z. Zhang, K. Long, A. V. Vasilakos, and L. Hanzo, "Full-duplex wireless communications: Challenges, solutions, and future research directions," *Proceedings of the IEEE*, vol. 104, pp. 1369-1409, July 2016.
17. D. Bharadia, E. McMillin, and S. Katti, "Full duplex radios," *SIGCOMM Comput. Commun. Rev.*, vol. 43, pp. 375-386, Aug. 2013.
